

GREASED FOR LIFE  
 PLATED STANDARD SHAFT  
 CONSULT FACTORY FOR  
 SPECIAL SHAFT CONFIGURATIONS.

RATIO: 6:1  
 MECH. ADVANTAGE: 4.8  
 TORQUE: 12,000 IN LBS  
 [1356 N-M]  
 TEMPERATURE: -20° TO 150°F  
 [-29° TO 66°C]  
 WEIGHT: 34 LBS [15.5 KGS]

SPUR FOR MANUAL 1/4 TURN ACTUATOR  
 COMMERCIAL GRADE

**DYNATORQUE**

1934 E. SHERMAN MUSKEGON, MI 49444-1824  
 (231) 739-1377 FAX (231) 739-4514  
 WWW.DYNATORQUE.COM

**SPUR**  
**6:1**

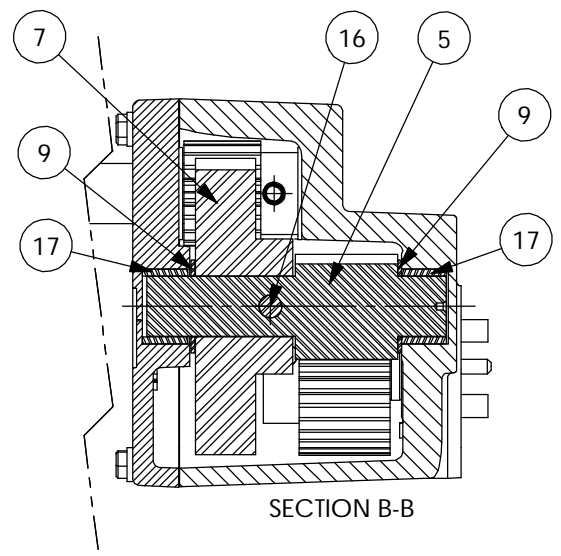
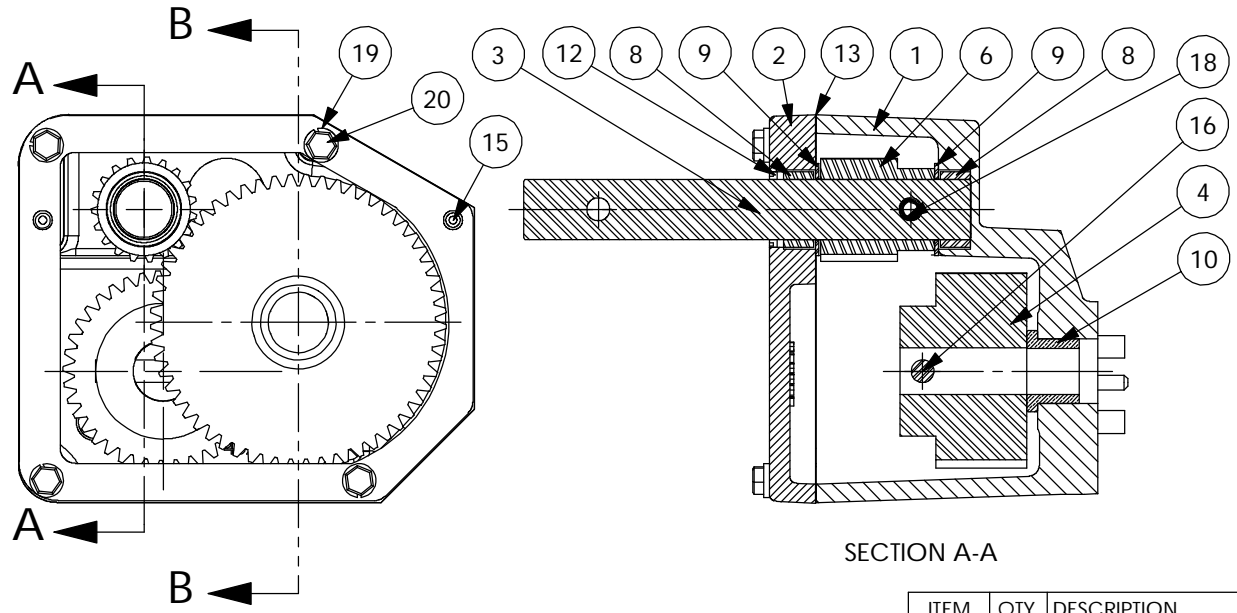
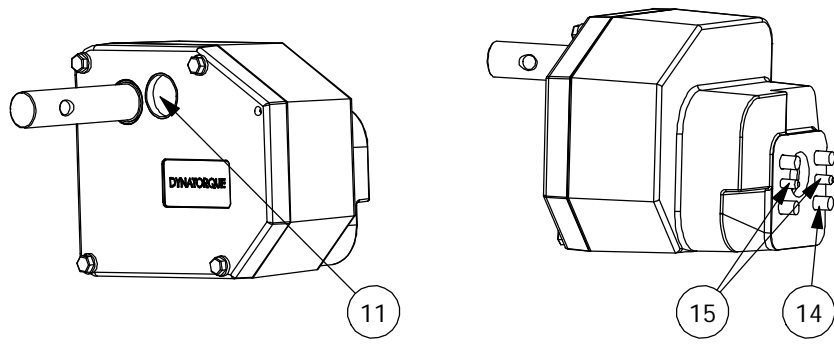

SECTION A-A

SECTION B-B

(COVER REMOVED IN THIS VIEW)

- 21 UNIT IS GREASED FOR LIFE.
- 22 UNIT IS PAINTED BLACK OXIDE.

ITEM	QTY.	DESCRIPTION	ITEM	QTY.	DESCRIPTION
1	1	HOUSING, SPUR, BLANK	15	4	DOWEL PIN, .250, .75
2	1	COVER, SPUR, BLANK	16	2	GROOVE PIN, .375, 2.25
3	1	SHAFT, SPUR, (NEW)	17	2	NEEDLE BEARING, B-1612
4	1	GEAR, SPUR, OUTPUT	18	1	COIL PIN, .375, 1.25
5	1	GEAR, SPUR, IDLER	19	4	WASHER, SPLIT, .250
6	1	GEAR, SPUR, INPUT	20	4	HHCS, 1/4-20 X 1.25 LG
7	1	GEAR, SPUR, 6:1	21	1	GREASE, COMMERCIAL GRADE
8	2	NEEDLE BEARING, BH168	22	1	BLACK OXIDE
9	4	THRUST WASHER, 1.00, .061			
10	1	BEARING, FLANGED, 1.25, 1.00, .88			
11	1	EXPANSION PLUG, 1.250, .31			
12	1	LIP SEAL, 1.00			
13	1	GASKET, COVER, SPUR			
14	4	SHCS, 3/8 X 1.00			

**DYNATORQUE**  
 1934 EAST SHERMAN BLVD  
 MUSKEGON, MI 49444-1824  
 (231) 739-1377 FAX (231) 739-4514  
 WWW.DYNATORQUE.COM

**6:1  
 SPUR**