

LOCATE HOOP WELD SEAM  
AT END OF SPOKE.  
SURFACE TO BE  
SMOOTH AND FLUSH.

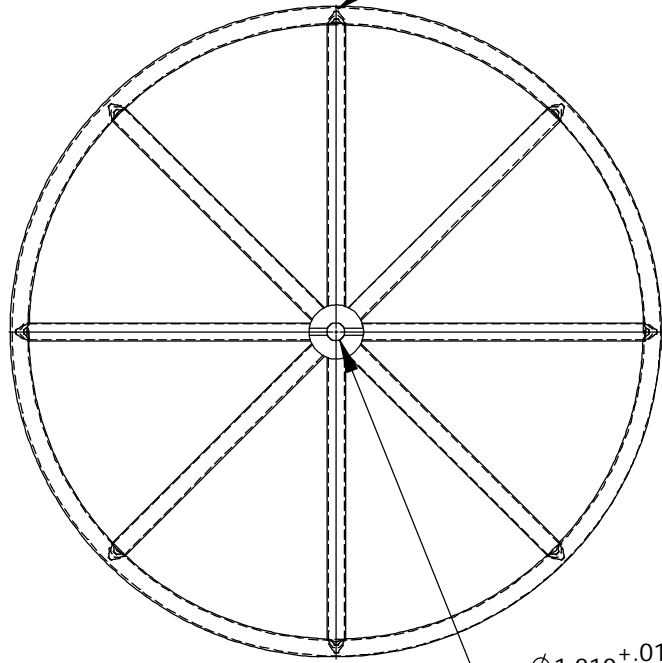

PAINT: BLACK EPOXY POWDERCOAT  
CONSTRUCTION: WELDED  $\phi 1.00$  STEEL TUBING

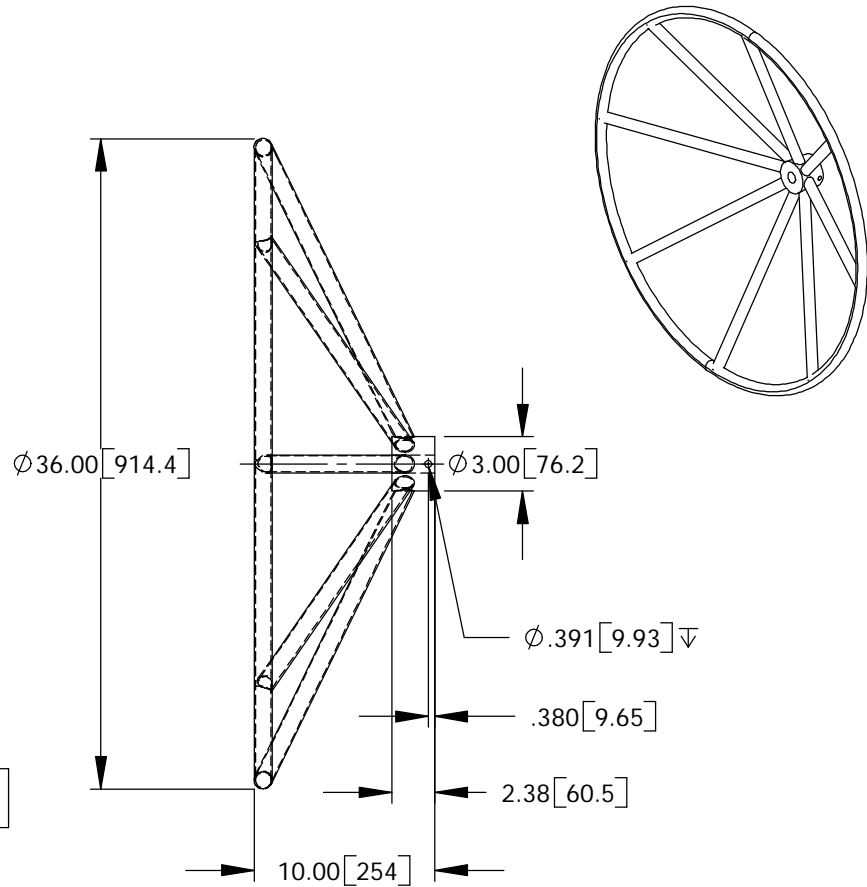

NOTE: 1. MOUNTING HARDWARE INCLUDED.  
2. SEAL WELD ALL JOINTS, WITH ALL ROUGH  
EDGES & WELD SPATTER REMOVED.

	1/13/03 BMA TWD	DATE BY	CHKD	<p>This drawing, the structural design disclosed therein and the technical data and engineering service represented thereby are the exclusive property of Dyna-Torque Incorporated. It is to be returned to Dyna-Torque upon written request and it is not to be reproduced in whole or in part or disclosed to anyone else without the express written consent of Dyna-Torque Incorporated.</p>	<p>TOLERANCE UNLESS NOTED</p> <p>X ± .06 XX ± .02 XXX ± .005 DEGREE ± 1/2°</p>	<p><b>DYNATORQUE</b> 1934 EAST SHERMAN BLVD MUSKEGON, MI 49444-1824 (231) 739-1377 FAX (231) 739-4514</p>	
	REDRAWN IN SW ER# 12782	DESCRIPTION			HW	<p>NAME OF PART <b>HWRR36</b></p>	
	REV					<p>NOTE</p>	
	C					<p>PART NO. <b>11-325</b></p>	<p>REV <b>C</b></p>