

CONSULT FACTORY FOR SPECIAL SHAFT & INDICATOR CONFIGURATIONS

33-25XXW SHEET 1 OF 2 8/28/03

<p>POS 1 POS 2 (STD)</p>		<p>KEYWAY DIAGRAM</p> <p>IN OPEN POS.</p>	<p>300 FT-LB STOPS BRONZE WORM WHEEL GREASED FOR LIFE PLATED STANDARD SHAFT MAX STEM HEIGHT: 2.75 [69.9] WORM WHEEL RECESS: .35 [8.9]</p>	<p>HANDWHEEL</p> <p>RECOMMENDED ϕ: 24 IN RIM PULL AT MAX TORQUE: 82 LBS TURNS FOR 90°: 7.5</p>	<p>RATIO: 30:1 TORQUE: 8,000 IN LBS [904 N-M] TEMPERATURE: -20° TO 150°F [-29° TO 66°C] EST. WEIGHT: 19 LBS [8.6 KGS]</p>			
<p>HOUSING MOUNTING PATTERN</p>				<p>BORE & KEY</p>			<p>MANUAL 1/4 TURN ACTUATOR AWWA GRADE</p>	
MAX	MAX ON CENTER	STD	MIN	MAX	STD	MIN	<p>DYNATORQUE DT8W</p> <p>1934 E. SHERMAN MUSKEGON, MI 49444-1824 (231) 739-1377 FAX (231) 739-4514 WWW.DYNATORQUE.COM</p>	
$\phi 5.125$ 1/2-13 UNC	$\phi 4.250$ 1/2-13 UNC	$\phi 5.000$ 1/2-13 UNC	$\phi 3.125$ 3/8-16 UNC	$\phi 1.875$.50 X .375 KEY	$\phi 1.750$.375 KEY @C	$\phi .391$		

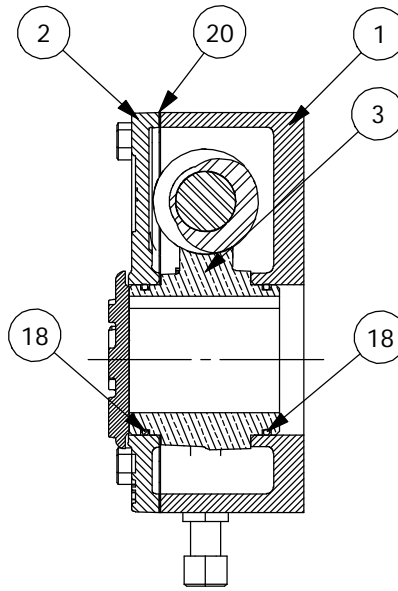
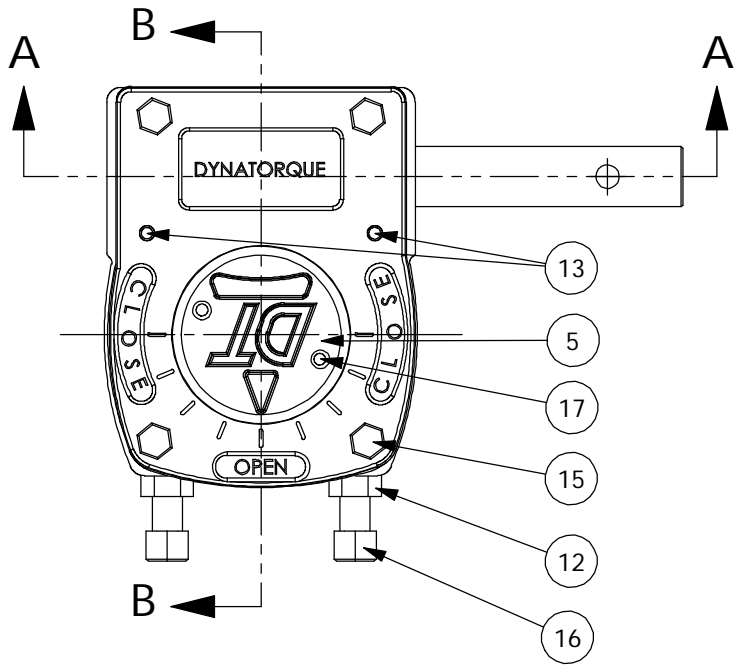

SECTION B-B

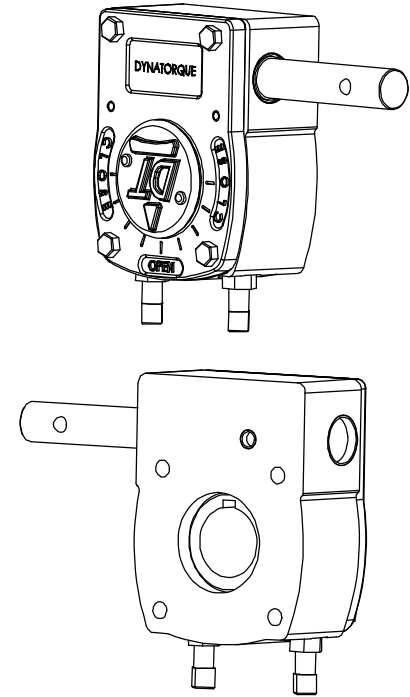

- 9 UNIT BEARINGS, O-RINGS AND GEAR TEETH ARE GREASED.
- 21 UNIT IS PAINTED BLACK OXIDE.

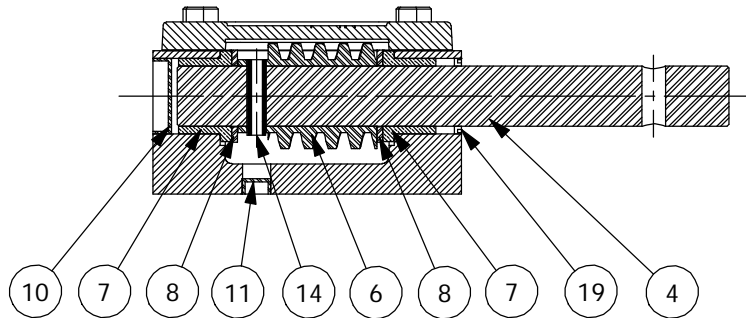

SECTION A-A

ITEM	QTY.	DESCRIPTION	ITEM	QTY.	DESCRIPTION
1	1	HOUSING, DT8	14	1	COIL PIN, .313, 1.25
2	1	COVER, DT8	15	4	HHCS, 3/8-16 X .875
3	1	W/WHEEL, DT8W	16	2	SET SCREW, SQ HD, 3/8-16 X .875
4	1	SHAFT, DT12, STD	17	2	PHCS, 8-32, S/TAP, 1.0
5	1	INDICATOR, DT7/DT8, STD	18	2	O-RING, 2-141
6	1	WORM, DT8	19	1	LIP SEAL, 1.00
7	2	BEARING, FLANGED, 1.25, 1.00, .88	20	1	COVER GASKET, DT8
8	2	THRUST WASHER, 1.00, .092	21	1	BLACK OXIDE
9	1	GREASE, COMMERCIAL GRADE			DYNATORQUE 1934 EAST SHERMAN BLVD MUSKEGON, MI 49444-1824 (231) 739-1377 FAX (231) 739-4514 WWW.DYNATORQUE.COM
10	1	EXPANSION PLUG, 1.250, .31			
11	1	EXPANSION PLUG, .468, .250			
12	2	NUT, JAM, 1/2-13, 316 SS			
13	2	DOWEL PIN, .250, .75			

DT8W