

CONSULT FACTORY FOR SPECIAL SHAFT AND INDICATOR CONFIGURATIONS.

						GREASED FOR LIFE PLATED STANDARD SHAFT MAX STEM HEIGHT: 4.12 [104.6] WORM WHEEL RECESS: .41 [10.4]		<b>HANDWHEEL</b> RECOMMENDED $\phi$ : 20 IN RIM PULL AT MAX TORQUE: 82 LBS TURNS FOR 90°: 53		RATIO: 212:1 TORQUE: 50,000 IN LBS [5656 N-M] TEMPERATURE: -20° TO 150 °F [-29° TO 66 °C] EST. WEIGHT: 105 LBS [48 KGS]	
<b>HOUSING MOUNTING PATTERN</b>				<b>BORE &amp; KEY</b>			<b>MANUAL 1/4 TURN ACTUATOR COMMERCIAL GRADE</b>				
MAX	MAX ON CENTER	STD	MIN	MAX	STD	MIN	<b>DYNATORQUE DT50</b> WWW.DYNATORQUE.COM 1/10/06				
$\phi$ 10.250 3/4-10 UNC	$\phi$ 10.250 3/4-10 UNC	$\phi$ 6.496 3/4-10 UNC	$\phi$ 6.000 5/8-11 UNC	$\phi$ 4.000 1.00 X .75 KEY	$\phi$ 3.250 .750 KEY @C	$\phi$ 1.625					

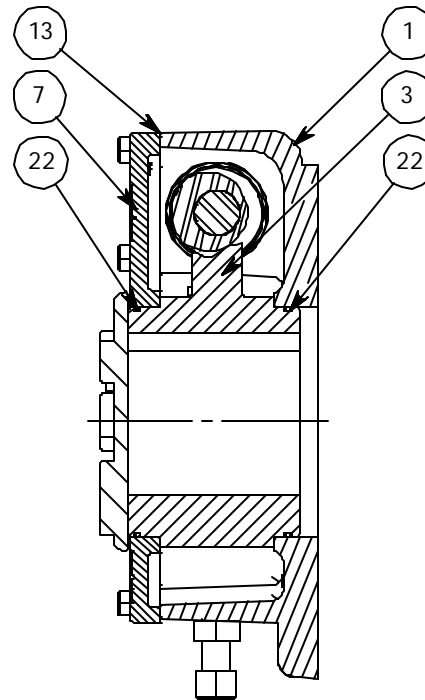

SECTION A-A

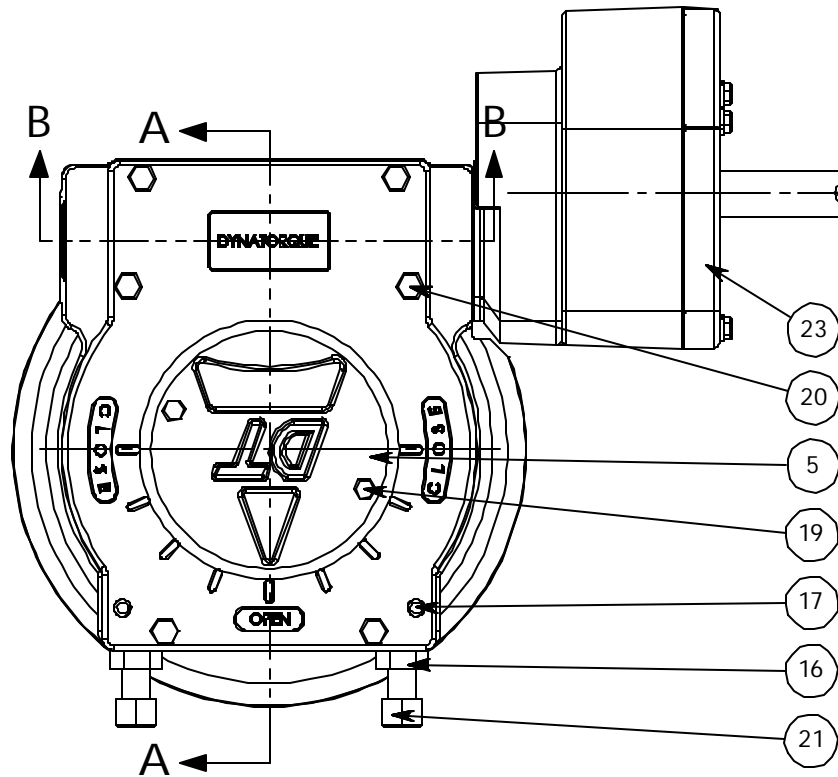
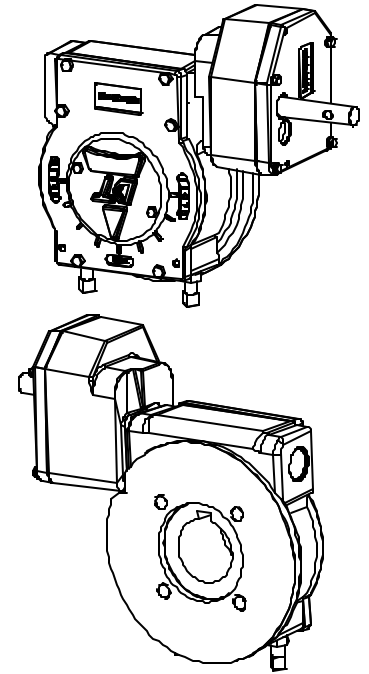

- 6 UNIT IS PAINTED BLACK OXIDE.
- 11 UNIT BEARINGS, ORINGS AND GEAR TEETH ARE GREASED.

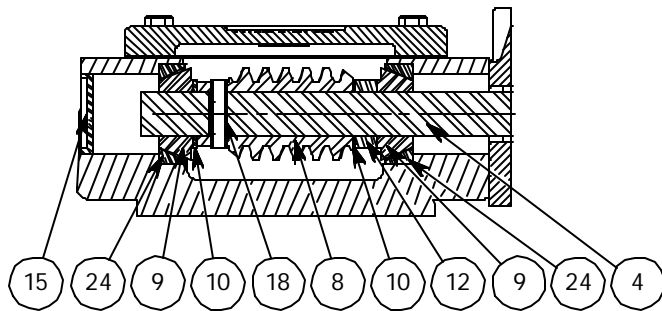

SECTION B-B

ITEM	QTY.	DESCRIPTION	ITEM	QTY.	DESCRIPTION
1	1	HOUSING, DT36	16	2	NUT,JAM,5/8-11
2	1	PLASTIC PLUG FOR SHIPPING	17	2	DOWEL PIN, .375,1.00
3	1	W/WHEEL,DT36	18	1	COIL PIN, .375,1.50
4	1	SHAFT,DT90	19	2	HHCS,1/4-20 X .75 LG
5	1	INDICATOR,DT36,STD	20	6	HHCS, 3/8-16 X 1.25 LG
6	1	PAINT, PRIMER, BLACK OXIDE	21	2	SHSS, 5/8-11 X 4.00
7	1	COVER,DT36,BLANK	22	2	O-RING,2-157
8	1	WORM,DT36	23	1	SPUR, 4:1
9	2	ROLLER BRG, CONE	24	2	ROLLER BRG, CUP
10	2	THRUST WASHER,1.00,.061			
11	1	GREASE, COMMERCIAL GRADE			
12	1	SPACER			
13	1	GASKET,DT36			
14	1	----			
15	1	EXPANSION PLUG,1.75,.23			

**DYNATORQUE** DT50  
 WWW.DYNATORQUE.COM  
 1/10/06