

CONSULT FACTORY FOR SPECIAL CONFIGURATIONS.

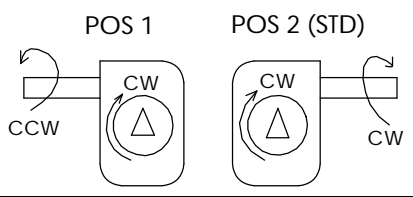

SPRING HANDLE LOCKS UNIT IN ENGAGED OR DISENGAGED POSITION.  
 UNIT SHOWN IN ENGAGED POSITION.  
 GREASED FOR LIFE.  
 PLATED STANDARD SHAFT.

MAX DRIVER BORE & KEY	
MAX IN LINE	MAX
Ø 1.500 .375 X .250 KEY	Ø 1.875 .500 X .375 KEY

**HANDWHEEL**  
 RECOMMENDED Ø: 24 IN  
 RIM PULL AT  
 MAX TORQUE: 133 LBS  
 TURNS FOR 90°: 15

RATIO: 60:1  
 TORQUE: 21,000 IN LBS  
 [2373 N-M]  
 TEMPERATURE: -20° TO 150°F  
 [-29° TO 66°C]  
 WEIGHT  
 UNIT: 41 LBS [1.6 KG]  
 DRIVER: 13 LBS [5.9 KG]  
 HANDWHEEL: 8 LBS [3.6 KG]

HOUSING MOUNTING PATTERN				COVER MOUNTING PATTERN			
MAX	MAX ON CENTER	STD	MIN	MAX	MAX ON CENTER	STD	MIN
Ø 7.000 3/4-10	Ø 5.250 1/2-13	Ø 5.512 5/8-11	Ø 4.500 5/8-11	Ø 7.750 Ø .812	Ø 5.875 Ø .562	Ø 5.512 Ø .688	Ø 5.500 Ø .562

**MANUAL 1/4 TURN ACTUATOR  
 COMMERCIAL GRADE**

**DYNATORQUE**

1934 E. SHERMAN MUSKEGON, MI 49444-1824  
 (231) 739-1377 FAX (231) 739-4514  
 WWW.DYNATORQUE.COM

**DT21  
 SD**

40-41XX SHEET 1 OF 2 8/6/03

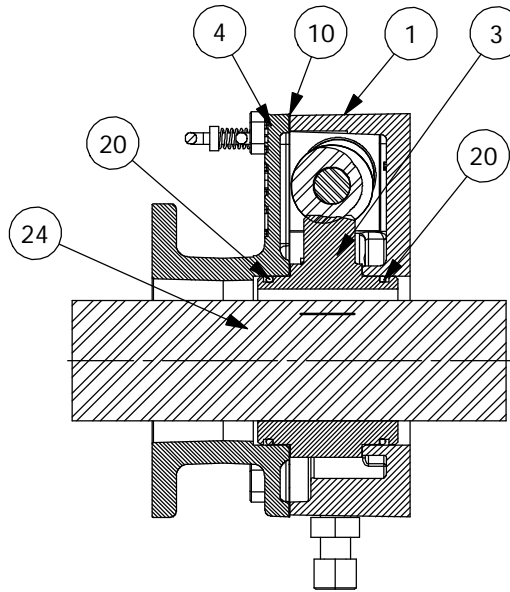
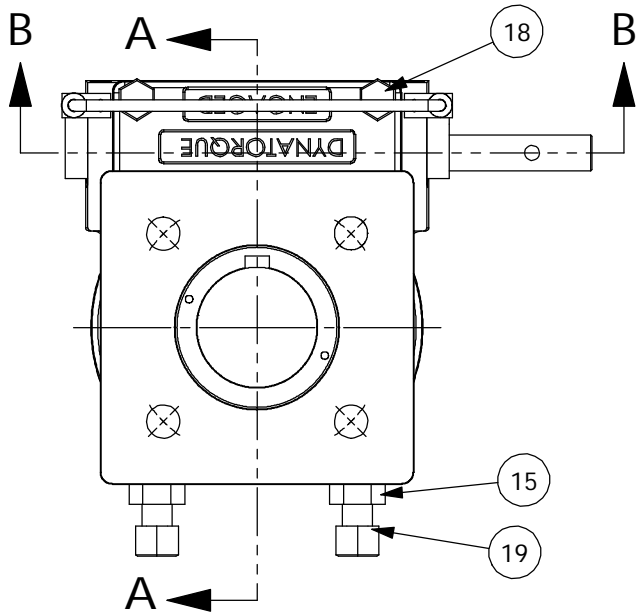

SECTION A-A

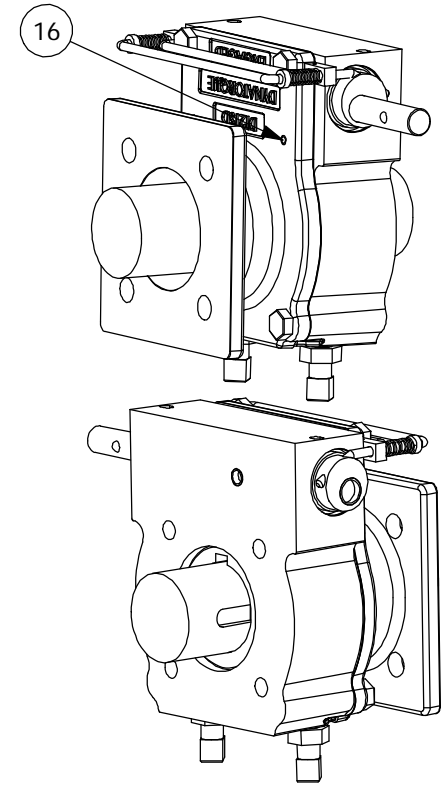

- 12 UNIT BEARINGS, O-RINGS AND GEAR TEETH ARE GREASED.
- 23 UNIT IS PAINTED BLACK OXIDE.
- 25 HWRR 24" HANDWHEEL NOT SHOWN.

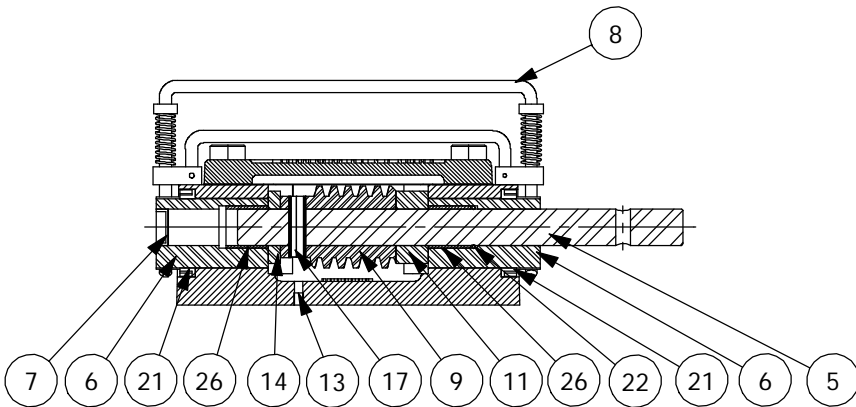

SECTION B-B

ITEM	QTY.	DESCRIPTION	ITEM	QTY.	DESCRIPTION
1	1	HOUSING,DT21SD	17	1	COIL PIN,.375,1.25
2	4	PLASTIC PLUG FOR SHIPPING	18	4	HHCS, 1/2-13 X 1.00 LG
3	1	W/WHEEL,DT21	19	2	SHSS, 5/8-11 X 3.00
4	1	COVER,DT21SD	20	2	O-RING,2-236
5	1	SHAFT, DT12SD/21SD, STD	21	2	LIP SEAL, 1.5
6	2	DECLUTCH BUSHING, DT12/21SD, SS	22	1	O-RING,2-018
7	1	EXPANSION PLUG,.750,.25	23	1	BLACK OXIDE
8	1	DECLUTCH HANDLE, DT21SD, SS	24	1	DR SRD, DT21, BLANK
9	1	WORM,DT21	25	1	HWRR 24"
10	1	COVER GASKET,DT16/21	26	2	BEARING SLV,.875,.750,.88
11	1	SPACER			
12	1	GREASE, COMMERCIAL GRADE			
13	1	EXPANSION PLUG,.468,.250			
14	1	SPACER			
15	2	NUT,JAM,5/8-11			
16	2	DOWEL PIN,.250,.75			

**DYNATORQUE**  
 1934 EAST SHERMAN  
 MUSKEGON, MI 49444-1824  
 (231) 739-1377 FAX (231) 739-4514  
 WWW.DYNATORQUE.COM

**DT21  
SD**