

22-200XX SHEET 1 OF 2 3/30/04

MOUNTING PATTERN			DRIVE PATTERN	RATIO: 3:1 THRUST: 22,000 LBS [90 KN] TORQUE: 625 FT-LB [848 N-M] TEMPERATURE: -20° TO 150°F [-29° TO 66°C] WEIGHT: 26 LBS [11.8 KGS] GREASED FOR LIFE PLATED STANDARD SHAFT	MANUAL MULTI-TURN ACTUATOR COMMERCIAL GRADE	
STD	MIN	MAX	STD		<b>DYNATORQUE</b>	<b>BG3</b>
$\phi 5.512$ 5/8-11 UNC	$\phi 4.016$ 3/8-16 UNC	$\phi 6.000$ 5/8-11 UNC	$\phi 2.844$ (6)5/16-18 UNC	1934 E. SHERMAN MUSKEGON, MI 49444-1824 (231) 739-1377 FAX (231) 739-4514 WWW.DYNATORQUE.COM		

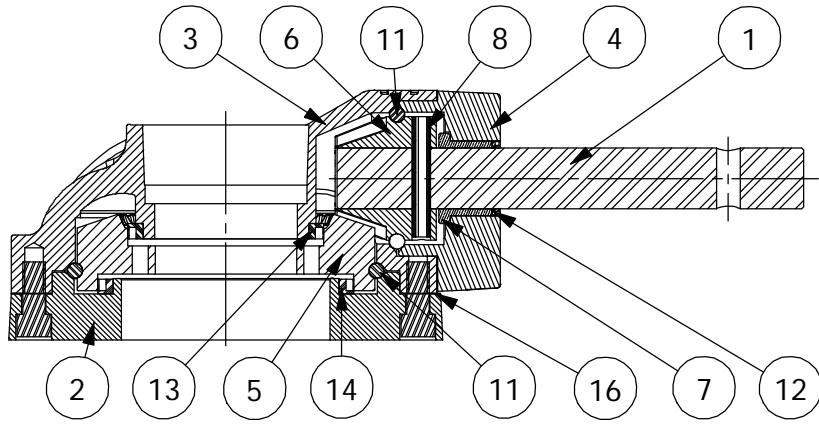

SECTION A-A

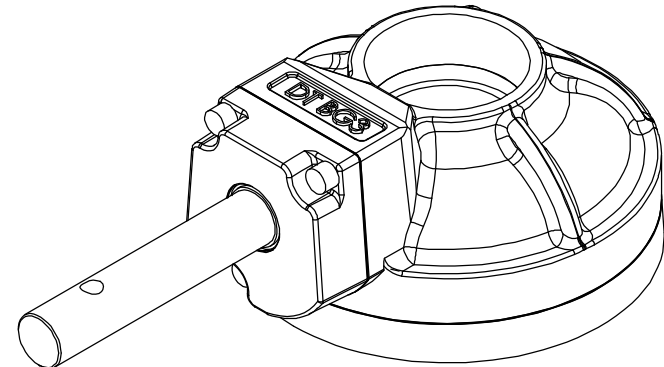
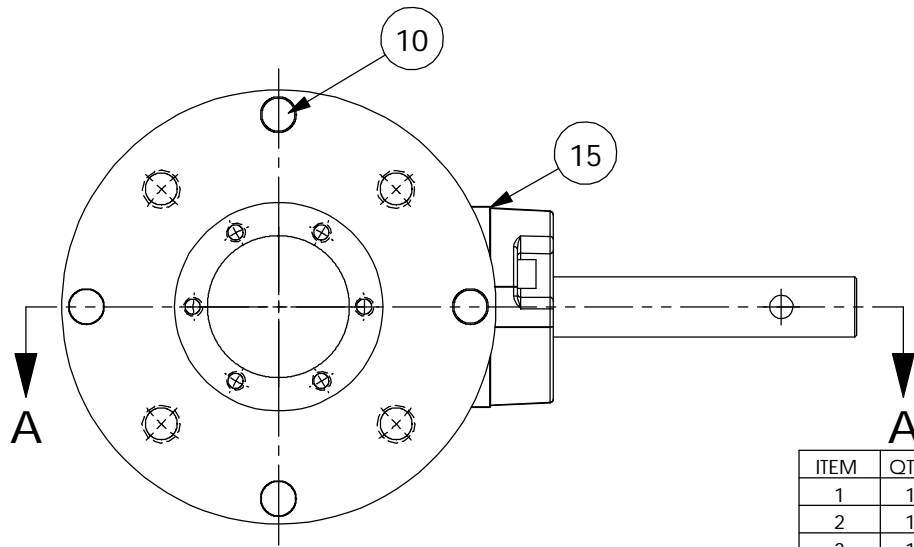
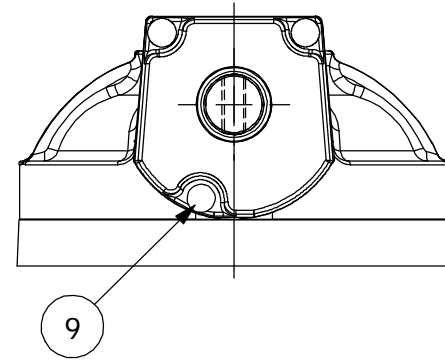

- 17 UNIT IS PAINTED BLACK OXIDE.
- 18 UNIT BEARINGS & GEAR TEETH ARE GREASED.

ITEM	QTY.	DESCRIPTION	ITEM	QTY.	DESCRIPTION
1	1	SHAFT,BG3	13	1	LIP SEAL,2.75
2	1	RETAINER, BG3	14	1	LIP SEAL,3.75
3	1	HOUSING, BG3, MACH	15	1	GASKET, BRG HSG, BG3
4	1	BRG HSG, BG3	16	1	GASKET, BRG RET, BG3
5	1	BEVEL GEAR, BG3, MACH	17	1	BLACK OXIDE
6	1	BEVEL PINION, BG3, MACH	18	1	GREASE, COMMERCIAL GRADE
7	1	BEARING,FLANGED,1.25,1.00,.88			
8	1	COIL PIN,.313,2.00			
9	3	SHCS, 5/16-18 X .875			
10	4	SHCS, 3/8-16 X .875			
11	89	BALL BEARING,.250 DIA			
12	1	LIP SEAL,1.00			

**DYNATORQUE**  
 1934 EAST SHERMAN BLVD  
 MUSKEGON, MI 49444-1824  
 (231) 739-1377 FAX (231) 739-4514  
 WWW.DYNATORQUE.COM

**BG3**