

AVAILABLE COUNTER CLOCKWISE OR CLOCKWISE TO CLOSE		GROUND LEVEL POSITION INDICATOR - SEALED 599-938 TURNS	
SHAFT DIAMETERS		NUMBER OF TURNS	
MIN.	MAX.	MIN.	MAX.
Ø .750 [19.05]	Ø 1.250 [31.75] STD.	599	938
		DYNATORQUE WWW.DYNATORQUE.COM 1/4/06	
		GPI-S 599-938	

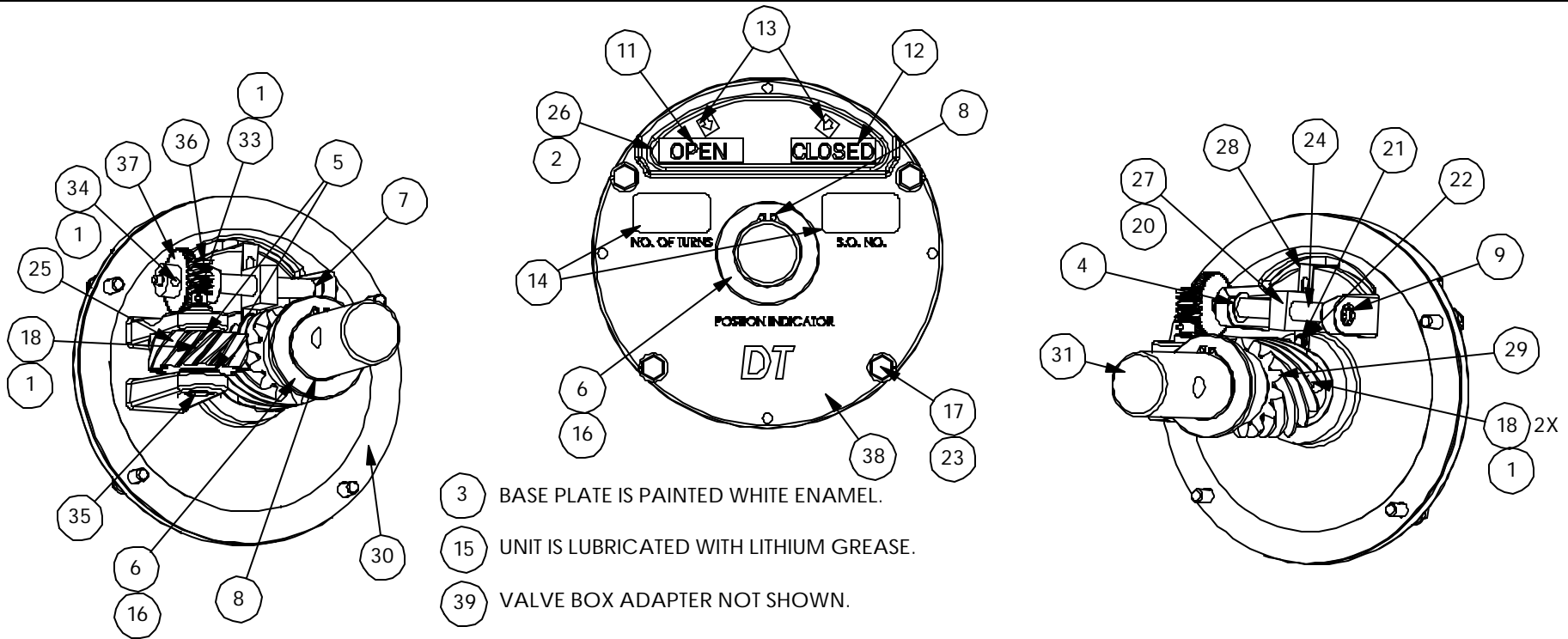

ITEM	QTY.	DESCRIPTION	ITEM	QTY.	DESCRIPTION
1	1	LOCTITE 271-21	21	1	RD HD,4-24,S/TAP,.25
2	1	SEALANT #732 RTV,DOW	22	1	WASHER,FLAT,#4,BRASS
3	1	PAINT, WHITE ENAMEL	23	4	WASHER,SPLIT,.250
4	1	PLASTIC BUSHINGS	24	1	TRAVELING NUT SHAFT
5	2	PLASTIC BUSHINGS	25	1	GEAR,DRIVEN, .50 BORE
6	2	BEARING,FLANGED,1.500,1.250,1.000	26	1	PI WINDOW
7	1	PLASTIC BUSHINGS	27	1	TRAVELING NUT PI
8	2	SNAP RINGS	28	1	PI INDICATOR POINTER
9	1	STAR RETAINING RING	29	1	GEAR,MAIN DRIVE 1.25 BORE
10	-	----	30	1	GASKET,PI
11	1	DECAL, "OPEN"	31	1	SHAFT, GPI-S, STD
12	1	DECAL, "CLOSED"	32	1	POSITION INDICATOR POT
13	2	DECAL, ARROW	33	1	SET SCREW, 4-40 X .125
14	2	ADEHESIVE TAG, FOIL	34	1	SET SCREW, 8-32, .25
15	1	GREASE, LITHIUM	35	1	DRIVE GEAR SHAFT, WPI
16	2	O-RING,2-214	36	1	WORM,PI
17	4	HHCS,1/4-20 X .88 LG	37	1	GEAR CHANGE GPI 499-3600
18	3	SET SCREW,1/4-20, .250	38	1	BASEPLATE, WPI,938
19	-	----	39	1	VAVE BOX ADAPTER FOR WPI - MACH
20	1	PAN HD,6-32,.25, S/TAP			

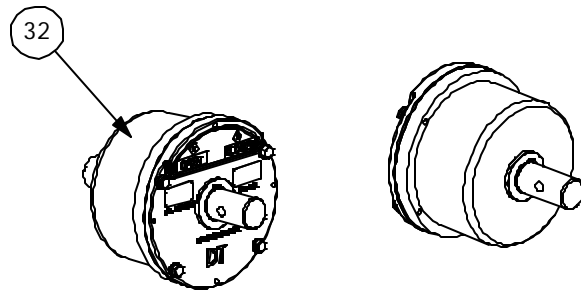

DYNATORQUE
 WWW.DYNATORQUE.COM
GPI-S
 599-938
 1/4/06