

- 3 BASE PLATE IS PAINTED WHITE ENAMEL.
- 15 UNIT IS LUBRICATED WITH LITHIUM GREASE.
- 38 VALVE BOX ADAPTER NOT SHOWN.

ITEM	QTY.	DESCRIPTION	ITEM	QTY.	DESCRIPTION
1	1	LOCTITE 271-21	20	1	PAN HD,6-32,.25, S/TAP
2	1	SEALANT #732 RTV,DOW	21	1	RD HD,4-24,S/TAP,.25
3	1	PAINT, WHITE ENAMEL	22	1	WASHER,FLAT,#4,BRASS
4	1	PLASTIC BUSHINGS	23	4	WASHER,SPLIT,.250
5	2	PLASTIC BUSHINGS	24	1	TRAVELING NUT SHAFT
6	2	BEARING,FLANGED,1.50,1.25,1.00	25	1	PI DRIVE GEAR,"SMALL"
7	1	PLASTIC BUSHINGS	26	1	PI WINDOW
8	2	SNAP RINGS	27	1	TRAVELING NUT PI
9	1	STAR RETAINING RING	28	1	PI INDICATOR POINTER
10	1	STAR RETAINING RING	29	1	GEAR,MAIN DRIVE
11	1	DECAL, "OPEN"	30	1	GASKET,PI
12	1	DECAL, "CLOSED"	31	1	SHAFT, GPI-S, STD
13	2	DECAL, ARROW	32	1	POSITION INDICATOR POT
14	2	ADEHESIVE TAG, FOIL	33	2	SET SCREW, 4-40 X .125
15	1	GREASE, LITHIUM	34	1	DRIVE GEAR SHAFT, WPI
16	2	O-RING,2-214	35	1	BEVEL GEAR, CHANGE, GPI, 20-38
17	4	HHCS,1/4-20 X .88 LG	36	1	BEVEL GEAR, CHANGE, GPI, 20-38
18	1	SET SCREW,1/4-20, .250	37	1	BASEPLATE, WPI
19	1	SET SCREW,1/4-20, .375	38	1	VAVE BOX ADAPTER FOR WPI - MACH

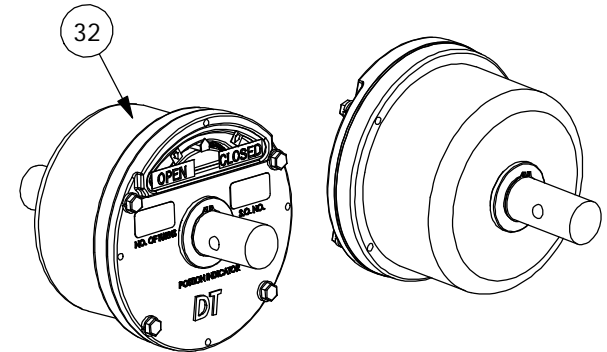

**DYNATORQUE**  
 1934 EAST SHERMAN BLVD  
 MUSKEGON, MI 49444-1824  
 (231) 739-1377 FAX (231) 739-4514  
 WWW.DYNATORQUE.COM

**GPI-S  
 20-38**