

NOTE: UNIT STAMPED WITH NO. OF TURNS AND SERIAL NUMBER.

CONSULT FACTORY FOR SPECIAL CONFIGURATIONS.

AVAILABLE COUNTER CLOCKWISE OR CLOCKWISE TO CLOSE

GROUND LEVEL POSITION INDICATOR - SEALED
199-298 TURNS

SHAFT DIAMETERS

NUMBER OF TURNS

MIN.

MAX.

MIN.

MAX.

ϕ .750 [19.05]

ϕ 1.250 [31.75]
STD.

199

298

DYNATORQUE

1934 E. SHERMAN MUSKEGON, MI 49444-1824
(231) 739-1377 FAX (231) 739-4514
WWW.DYNATORQUE.COM

GPI-S
199-298

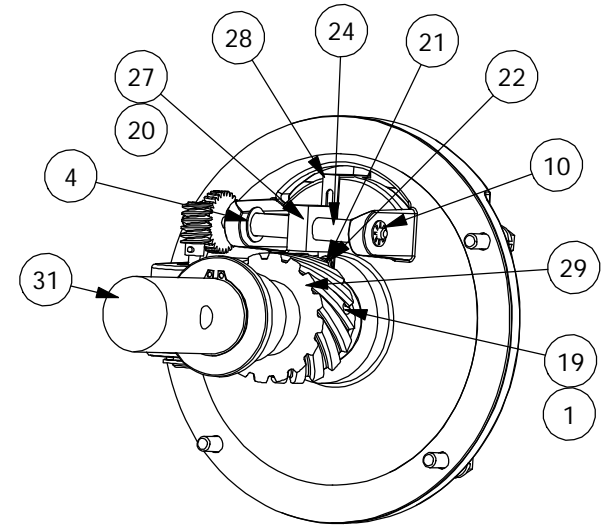
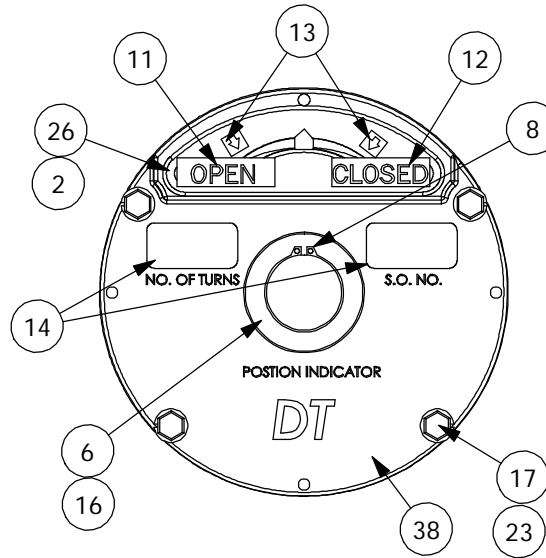
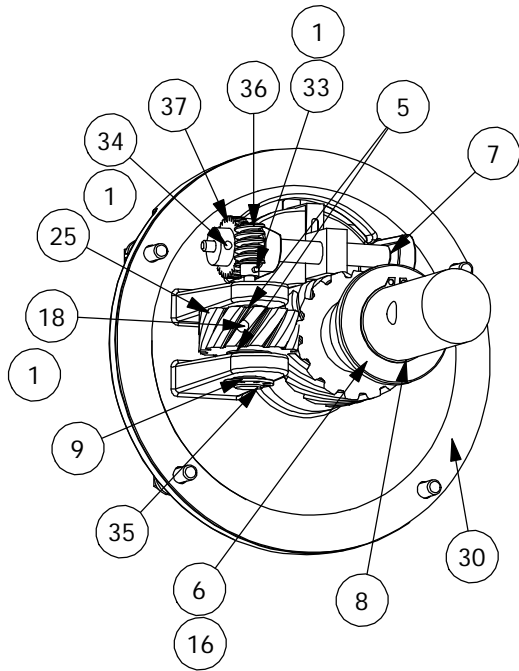

- 3 BASE PLATE IS PAINTED WHITE ENAMEL.
- 15 UNIT IS LUBRICATED WITH LITHIUM GREASE.
- 39 VALVE BOX ADAPTER NOT SHOWN.

ITEM	QTY.	DESCRIPTION	ITEM	QTY.	DESCRIPTION
1	1	LOCTITE 271-21	21	1	RD HD,4-24,S/TAP,.25
2	1	SEALANT #732 RTV,DOW	22	1	WASHER,FLAT,#4,BRASS
3	1	PAINT, WHITE ENAMEL	23	4	WASHER,SPLIT,.250
4	1	PLASTIC BUSHINGS	24	1	TRAVELING NUT SHAFT
5	2	PLASTIC BUSHINGS	25	1	PI DRIVE GEAR,"SMALL"
6	2	BEARING,FLANGED,1.50,1.25,1.00	26	1	PI WINDOW
7	1	PLASTIC BUSHINGS	27	1	TRAVELING NUT PI
8	2	SNAP RINGS	28	1	PI INDICATOR POINTER
9	1	STAR RETAINING RING	29	1	GEAR,MAIN DRIVE
10	1	STAR RETAINING RING	30	1	GASKET,PI
11	1	DECAL, "OPEN"	31	1	SHAFT, GPI-S, STD
12	1	DECAL, "CLOSED"	32	1	POSITION INDICATOR POT
13	2	DECAL, ARROW	33	1	SET SCREW, 4-40 X .125
14	2	ADEHESIVE TAG, FOIL	34	1	SET SCREW, 6-32 X .125
15	1	GREASE, LITHIUM	35	1	DRIVE GEAR SHAFT, WPI
16	2	O-RING,2-214	36	1	WORM,PI
17	4	HHCS,1/4-20 X .88 LG	37	1	GEAR CHANGE GPI 199-298
18	1	SET SCREW,1/4-20, .250	38	1	BASEPLATE, WPI
19	1	SET SCREW,1/4-20, .375	39	1	VAVE BOX ADAPTER FOR WPI - MACH
20	1	PAN HD,6-32,.25, S/TAP			

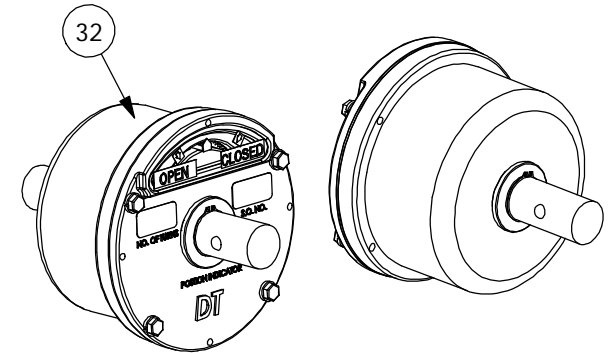

DYNATORQUE 1934 EAST SHERMAN BLVD MUSKEGON, MI 49444-1824 (231) 739-1377 FAX (231) 739-4514 WWW.DYNATORQUE.COM	GPI-S 199-298
---	--------------------------------