

25-245-148XX SHEET 1 OF 2 10/22/03

AVAILABLE COUNTER CLOCKWISE
OR CLOCKWISE TO CLOSE

GROUND LEVEL POSITION INDICATOR - STD
99 - 148 TURNS

SHAFT DIAMETERS

NUMBER OF TURNS

MIN.

MAX.

MIN.

MAX.

$\phi .750$ [19.05]

$\phi 1.250$ [31.75]
STD.

99

148

DYNATORQUE

1934 E. SHERMAN MUSKEGON, MI 49444-1824
(231) 739-1377 FAX (231) 739-4514
WWW.DYNATORQUE.COM

GPI

99-148

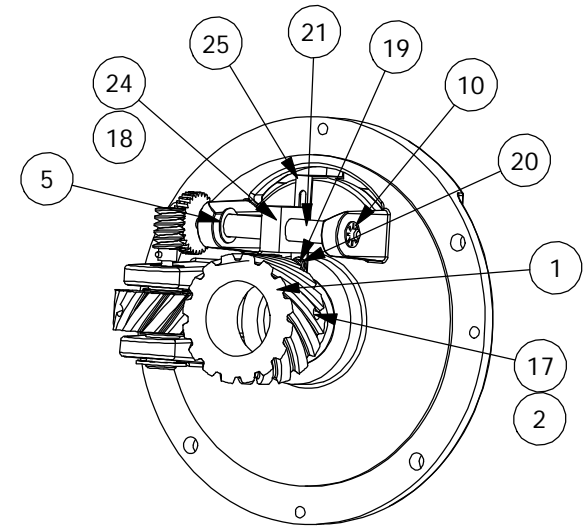
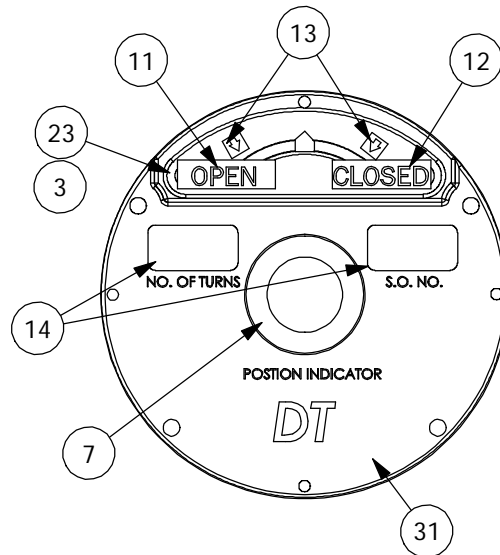
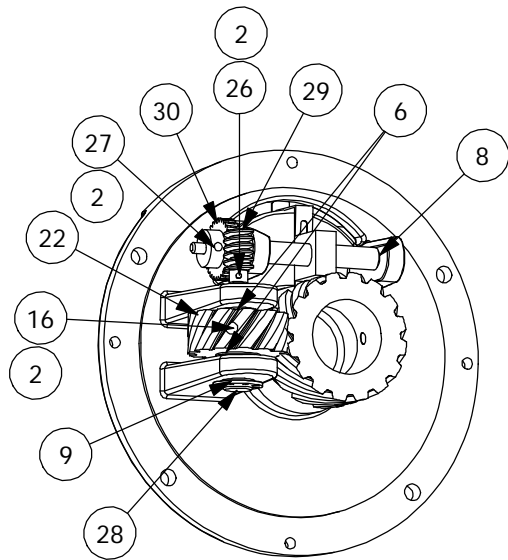

- 4 UNIT IS PAINTED WHITE ENAMEL.
- 15 UNIT IS LUBRICATED WITH LITHIUM GREASE.
- 32 VALVE BOX ADAPTER NOT SHOWN.

ITEM	QTY.	DESCRIPTION	ITEM	QTY.	DESCRIPTION
1	1	GEAR,MAIN DRIVE	17	1	SET SCREW,1/4-20, .375
2	1	LOCTITE 271-21	18	1	PAN HD,6-32,.25, S/TAP
3	1	SEALANT #732 RTV,DOW	19	1	RD HD,4-24,S/TAP, .25
4	1	PAINT, WHITE ENAMEL	20	1	WASHER,FLAT,#4,BRASS
5	1	PLASTIC BUSHINGS	21	1	TRAVELING NUT SHAFT
6	2	PLASTIC BUSHINGS	22	1	PI DRIVE GEAR,"SMALL"
7	1	BEARING,FLANGED,1.50,1.25,1.00	23	1	PI WINDOW
8	1	PLASTIC BUSHINGS	24	1	TRAVELING NUT PI
9	1	STAR RETAINING RING	25	1	PI INDICATOR POINTER
10	1	STAR RETAINING RING	26	1	SET SCREW, 4-40 X .125
11	1	DECAL, "OPEN"	27	1	SET SCREW, 6-32 X .125
12	1	DECAL, "CLOSED"	28	1	DRIVE GEAR SHAFT, WPI
13	2	DECAL, ARROW	29	1	WORM,PI
14	2	ADEHESIVE TAG, FOIL	30	1	GEAR CHANGE GPI 99-148
15	1	GREASE, LITHIUM	31	1	BASEPLATE, WPI
16	1	SET SCREW,1/4-20, .250	32	1	VAVE BOX ADAPTER FOR WPI - MACH

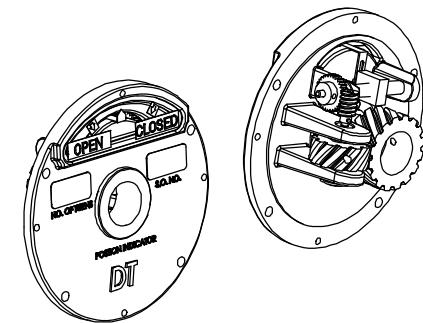

DYNATORQUE
 1934 EAST SHERMAN BLVD
 MUSKEGON, MI 49444-1824
 (231) 739-1377 FAX (231) 739-4514
 WWW.DYNATORQUE.COM

GPI
99-148